

# ***Farm Jack***



**IMPORTANT!** PLEASE READ THESE INSTRUCTIONS CAREFULLY. NOTE ALL SAFETY INSTRUCTIONS AND WARNINGS. USE THE PRODUCT CORRECTLY AND WITH CARE FOR THE PURPOSE FOR WHICH IT IS INTENDED. FAILURE TO FOLLOW THESE INSTRUCTIONS MAY CAUSE DAMAGE TO PROPERTY AND/OR PERSONAL INJURY.

**PLEASE KEEP THESE INSTRUCTIONS SAFE AND AVAILABLE FOR FUTURE REFERENCE.**

## **INTENDED USE**

---

This farm jack is a versatile mechanical tool which can be used for a variety of tasks. The jack can be used for the lifting of heavy loads, including but not limited to lifting vehicles, trailers and machinery as well as use in many utility tasks, such as tensioning wire fences or pulling out tree stumps.

## **SAFETY INSTRUCTIONS AND WARNINGS**

---

1. ALWAYS inspect the jack before use. Inspect for distortion of the column and locking pins and the security of all parts. Check all parts are in good condition and operating smoothly and that no cracks or distortion is apparent. If in doubt DO NOT use.
  2. If any part of the jack fails to work properly, stop use and have it repaired or replaced. NEVER attempt to repair the jack while it is under load.
  3. DO NOT use the jack for any purpose other than for which it is designed.
  4. Ensure the jack is on a firm solid base and that there is no likelihood of it slipping or sinking when under load.
  5. Ensure the load is taken by the FULL lifting nose and that the point of lift on the load is of sufficient strength to support the full load adequately.
  6. ALWAYS ensure that the load is stabilised or supported in such a way that it will not shift during lowering or lifting. Always lock and/or stabilise the load to be lifted. The jack will not act as a load stabiliser.
  7. ALWAYS use supports to stabilize the load once lifted. DO NOT rely upon the jack to hold the load in position.
  8. NEVER push a load off the jack.
  9. All persons shall be clear of load being raised, lowered or pulled. NEVER work under a raised load without using additional supports such as axle stands.
  10. Ensure there is a working gap between a vehicle being lifted and any adjacent wall or object.
  11. Ensure the vehicle handbrake is securely on and/or an automatic vehicle transmission is in the park position before lifting.
  12. Take care not to trap fingers within the moving parts.
  13. ALWAYS keep a firm grip on the handle and support beam.
  14. When using the jack to pull or drag a load, be aware that the load may suddenly 'give', e.g. pulling a tree stump etc. Take appropriate precautions.
  15. NEVER exceed the rated load of the jack as given in the specifications.
- WARNING: If you exceed rated capacity, the shear pin will break and the handle will drop.**
16. DO NOT use additional bars/tubes in conjunction with the handle to provide extra leverage. Use hand power only.
  17. NEVER carry the jack by the handle as the column may drop and cause harm to persons or property.
  18. ALWAYS ensure that the lifting head climbing pin is located and locked in a hole in the steel beam before releasing the pumping handle, otherwise the lifting head will automatically lower, causing the handle to move up and down rapidly presenting a risk of serious injury.
  19. The jack must have a minimum load of 50kg to activate the lowering step by step, otherwise lifting head will drop.

# TECHNICAL SPECIFICATIONS

Item	TJFAR048	TJFAR060
Rated load	2000 kg	1500 kg
Lifting height with rated load	125~1020mm	125~1320mm
Net Weight	12.6 kg	13.7 kg

# OPERATING INSTRUCTIONS

## Vertical Lifting

**Warning: Before lifting ensure safety precautions are read and understood.**

1. Before lifting assess the correct jacking point for the load. If the load is a vehicle consult the vehicle manufacturer's handbook for the correct lifting point.
2. Pull the direction latch (fig.1 H) upwards until it clicks into place. Ensure it is locked in place with the indentation on the latch firmly engaged with the notch on the reversing switch.
3. Ensure that the foot of the jack (fig.2 B) is placed on a stable, strong base capable of supporting the jack and the load. The foot of the jack should be immediately below the chosen lifting point so that the lifting action is vertical. DO NOT attempt a lift with the jack at an angle.
4. Raise the lifting toe to the jacking point on the load. The lifting head can be raised manually into position. You will hear the mechanism clicking as you do this.
5. Hold the beam (D) steady. Unclip the handle (E) by pulling it downwards and pump the handle up and down with a full stroke to bring the lifting toe into contact with the jacking point. Check that the toe is fully under the load and lifting at the right point.
6. When you are sure that the jack and load are stable commence lifting by pulling the handle down a full stroke. As the handle is pulled down you will hear the climbing pin click into place as it locates in the next hole in the steel beam. At this point, relax the handle allowing the pin to take the load. Raise the handle to the top of its stroke to take a fresh purchase and pump the handle down again. Pressure will be felt on the downward stroke. Always keep a firm grip on the handle.
7. No extension of any sort should be applied to the handle to gain extra leverage.
8. When the desired lifting height has been achieved, raise the handle towards the beam and clip it in the vertical position (fig.2 G).
9. Place an M12 steel bolt (not supplied) through the hole immediately below the lifting mechanism to act as a safety pin.

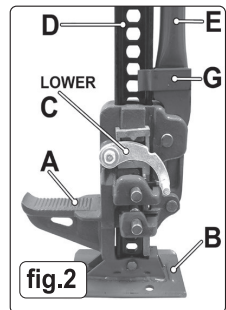
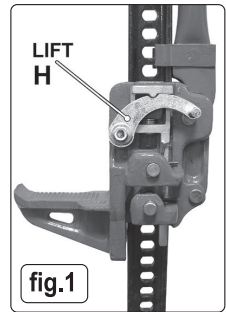

**Warning! The jack is for lifting or pulling, and must not be used to continuously support a load. Place axle stands or other appropriate supports beneath a vehicle/load.**

## Lowering a Load

**Warning! The jack must be loaded with a minimum of 50kg to lower step by step otherwise the lifting toe will drop rapidly to the bottom of the beam when the direction latch is moved to the lowering position.**

Jack the load up slightly, remove safety pin if fitted and any previously placed supports. Place the handle in the fully upright position. Trip the reversing latch so that it is in the down position with the indentation on the latch disengaged from the notch on the reversing switch (see fig.2C). Keeping a firm grip on the handle, commence lowering by pumping the handle steadily up and down. When lowering, you will feel resistance on the upward (or backward) stroke of the handle.

DO NOT RELEASE THE HANDLE UNTIL THE CLIMBING PIN HAS LOCKED INTO PLACE. IF THE CLIMBING PIN IS NOT LOCKED INTO PLACE AND THE HANDLE IS RELEASED, THE LIFTING HEAD WILL AUTOMATICALLY LOWER CAUSING THE HANDLE TO MOVE UP AND DOWN RAPIDLY, PRESENTING A RISK OF SERIOUS OR FATAL INJURY.

## Pulling, Tensioning and Positioning

1. The jack may be used for a variety of other purposes such as tensioning fences (See fig.5), pulling out tree stumps (See fig.4) and positioning of heavy items such as machinery. In all cases such operations should begin with a risk assessment exercise including consideration of the following points.
2. When the jack is used for pulling or tensioning there will be a tendency for the pulling force to move the beam away from the line of pull unless the far end of the beam is restrained or fixed using suitable chains, bolts, ropes etc. Any fixing/restraining items used must be sufficiently rated for the pulling force that will be applied to them.
3. Where other structures are used to stabilize the beam the operator must be certain that these structures are sufficiently strong to resist the force applied to them otherwise damage may occur to the structure resulting in a sudden and dangerous loss of tension.
4. When repositioning heavy items such as machinery consideration should be given to how the load will move once it is set in motion and sufficient precautions taken to restrain the item from moving too far or in an unpredictable way. Similar caution needs to be exercised when choosing attachment/pushing/pulling points on machinery. These points must be sufficiently strong to resist the forces applied to them.
5. It is the responsibility of the owner of the equipment to assess the safety requirements for every new usage of the equipment and to take sufficient safety precautions.

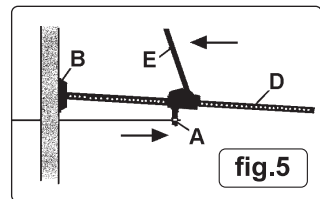
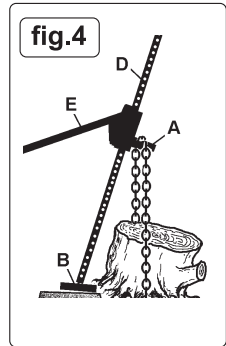
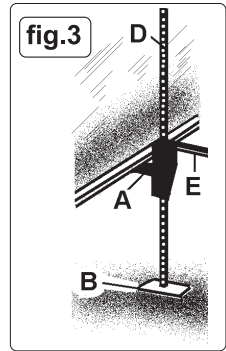

## EXPLODED PARTS DIAGRAM

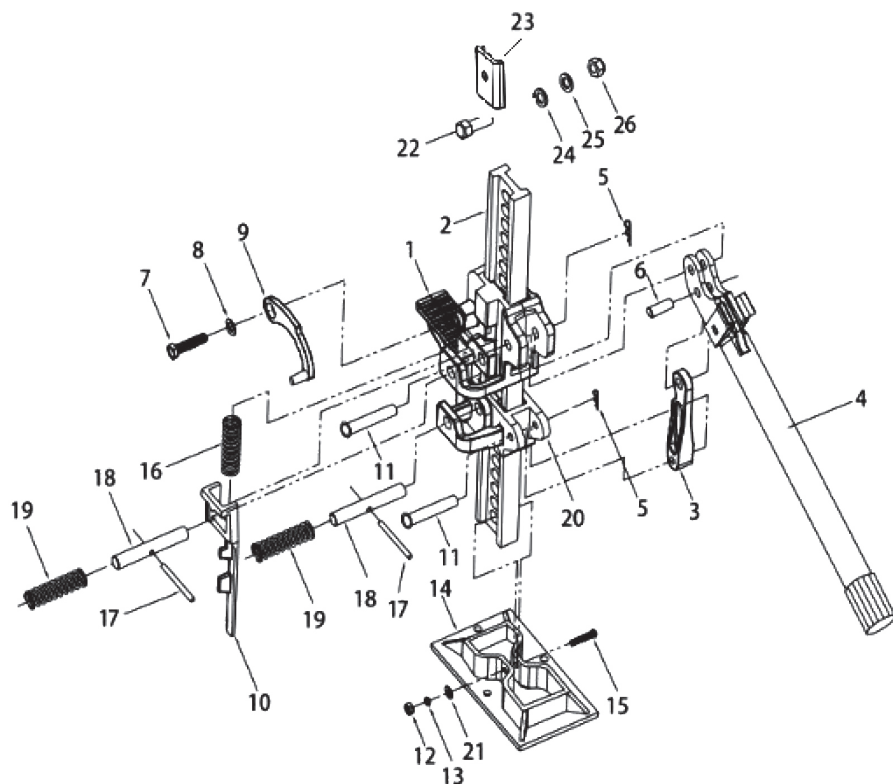

No.	Description	Qty
1	Lifting Arm	1
2	Steel Rail	1
3	Connecting Rod	1
4	Handle Assembly	1
5	R-Clip	2
6	Pin	1
7	Screw	1
8	Washer	1
9	Reversing Lever-Silver	1
10	Reversing Latch -Silver	1
11	Pin	2
12	Nut	1
13	Spring Washer	1

No.	Description	Qty
14	Base	1
15	Bolt	1
16	Spring	1
17	Reverse Rod Pin	2
18	Reverse Rod	2
19	Spring	2
20	Small Runner	1
21	Flat Washer	1
22	Screw	1
23	Stop Block	1
24	Flat Washer	1
25	Spring Washer	1
26	Nut	1

## ***MAINTENANCE***

---

1. Keep the moving parts clean and free from debris especially if used in a dirty environment e.g. for tree stump removals.
2. Keep all parts of the jack gently lubricated to prevent any possibility of corrosion, if stored for long periods.
3. Store in a dry, childproof location where it cannot be damaged by the elements.

## ***HELPLINE***

---

In the unlikely event of a defect occurring please contact our Helpline.

Office hours: Monday - Friday 9:00am - 5:00pm. Telephone Number 01332 576 850

# ***EC DECLARATION OF CONFORMITY***

---

1. **Product models:** TJFAR048, TJFAR060

2. **Name and address of the manufacturer or his authorised representative:**



SGS Engineering (UK) Ltd  
Unit 1 West Side Park, Raynesway, Derby, DE21 7AZ  
Telephone: +44 (0)1332 576 850

3. **This declaration of conformity is issued under the sole responsibility of the manufacturer.**

4. **Object of the declaration:**

**Equipment:** 48" FARM JACK  
60" FARM JACK

**Brand name:** SGS

5. **The object of the declaration described above is in conformity with the relevant statutory requirements:**

Machinery Directive 2006/42/EC

6. **References to the relevant designated standards used or references to the other technical specifications in relation to which conformity is declared:**

EN 1494:2000/A1:2008

7. **The person authorized to compile the technical file:**

**Name:** Neil Sansom

**Address:** SGS Engineering (UK) Ltd, Unit 1 West Side Park, Raynesway, Derby, DE21 7AZ

**Signed for and on behalf of:**

Authorised Representative

A handwritten signature in black ink, appearing to read 'Neil Sansom', written over a horizontal line.

Neil Sansom, CEO

**Date:** 03/25/2026

